

1. DESCRIPTION OF THE FRONT PANEL

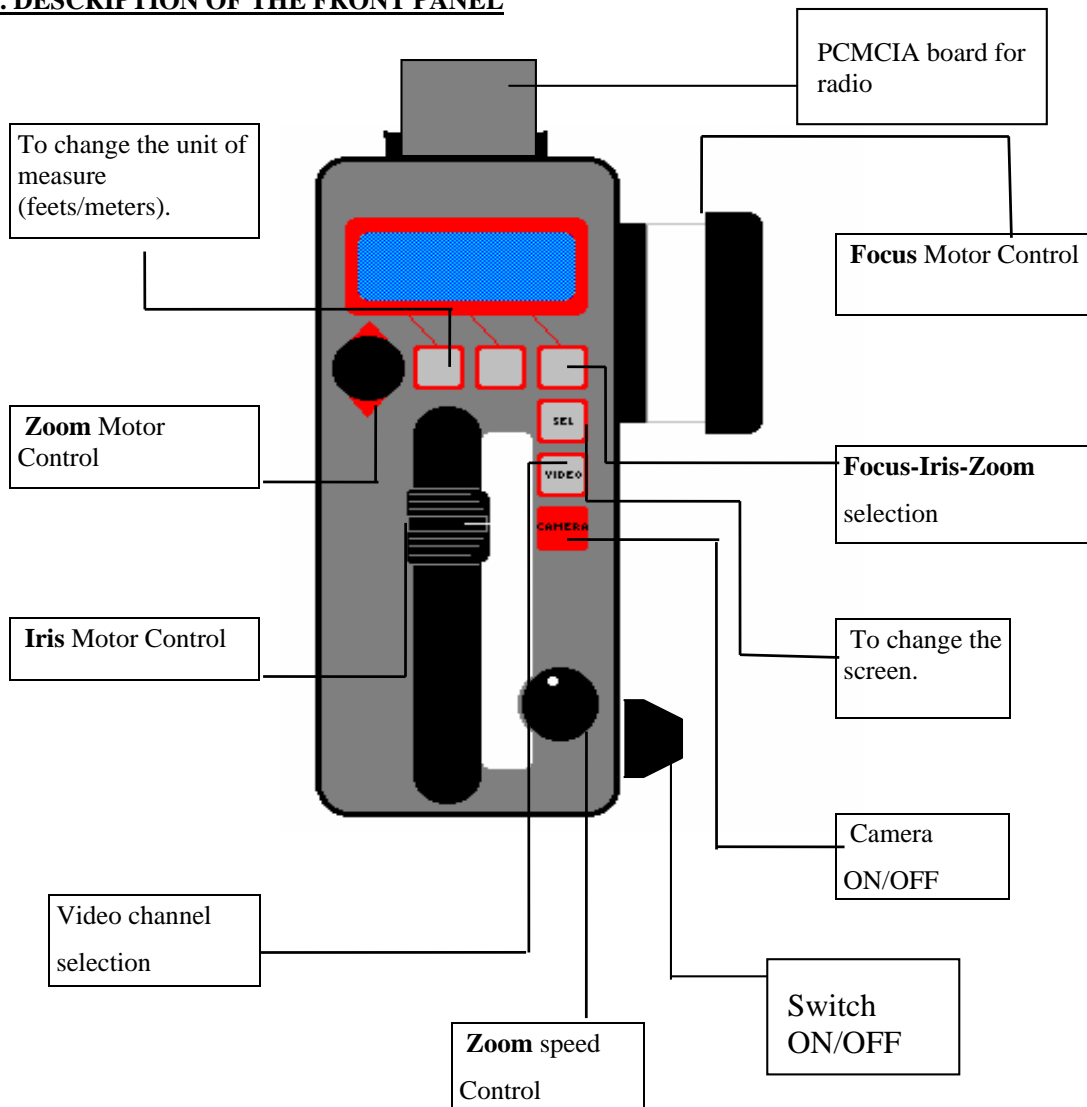

2. SWITCHING ON THE SYSTEM

2.1. Wire Operation

When you switch on the hand unit, and the system is functioning correctly, the following screen will appear for a few seconds:

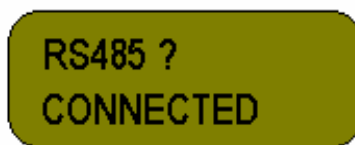

In the event that the cable linking the hand unit to the system is broken or short-circuited the following screen will appear:

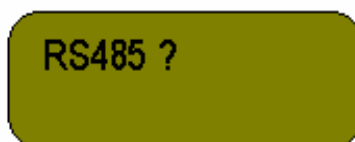

This is indicating that there is no communication between the hand unit and the control.

In the event that the system is radio operation, but the channel selected is Channel 0, the wireless channel, the following display will appear:

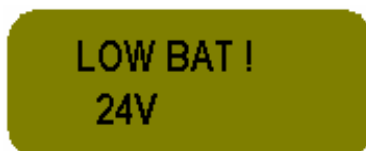

Then, switch off the Hand Unit and change the communication channel from cable to radio, such as it is described on Limit adjustments on page 8 of this manual.

2.2. Wireless Operation

After switching on the hand unit the following screen will appear for a few seconds:



In the event that the channel selected on the hand unit does not correspond with the channel selected on the Motor Driver box; the system will stay blocked displaying the following screen until the channels are matched

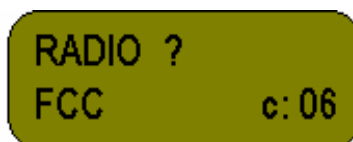

The system conforms fully to all American standardized regulations regarding wireless communication devices. It is important to ALWAYS SET YOUR SYSTEM TO OPERATE ACCORDING TO THE REGULATIONS IN THE AREA YOU ARE OPERATING IN. (EXAMPLE: For operation in the United States, the unit must be set for FCC operation) Changing standard settings is described on page 7 of this manual.

There are 11 communication channels while operating by radio, 1-2-3-4-5-6-7-8-9-A-B (A for channel 10 and B for channel 11). Series Channel 0 is used when operating with cable.

The rest of the operation is the same for wired or radio connection.

Next, from this screen you can select either 16 mm or 35 mm application.

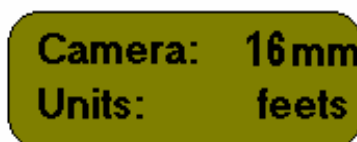

3. RESET ALL?

Servicevision System S.A. SCORPIO FOCUS
After switching on the system, this menu asks if you want to reset the settings that have been previously recorded before you last switched off the system. Select "no" if you would like the systems to retain

all previous programs, lens calibrations and range limits. If you would like to reset the entire system, simply answer "yes".

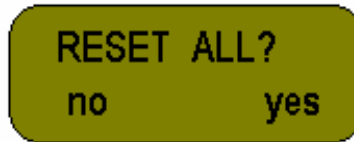

4. MAIN SCREEN (speed and feet shot)

FOR WIRED OPERATION

A small letter on the right side of the panel indicates the condition of the series channel communication between the components in the system. If the letter is a "C" there is communication. If the letter is an "N" there is no communication.

FOR RADIO OPERATION

If the command contacts the system it means that we are within the permitted distance for communication by radio. A "Y" will appear on the screen. In the event you begin to travel out of range, part of letter "Y" will progressively disappear until it vanishes completely. When this letter disappears, you have lost communication completely (indicated by letter "N"), and the system will not respond.

Furthermore, the system indicates the condition of the FIZ motors. In the event that one of the motors cannot reach the position indicated through the hand unit potentiometers (because of a jam or problem with the optics), a letter **F**, **I** or **Z** will appear indicating which motor/s haven't reached the position.

This screen also tells you the speed of the camera, the meters or feet of the film used, the duration of the last take (also in feet or meters) and also if the camera is on or off:

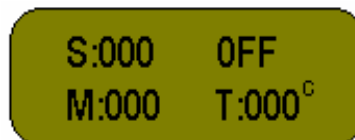

- | | |
|---|----------------------------------|
| - Speed of the camera: | S: 000 |
| - Feet or meters shot: | F: 000
(M: 000) |
| - Duration of last take (meters or feet): | T: 000 |
| - Camera on or off: | ON (OFF) |

From this screen you can change the measure unit of used film from feet to meters or vice versa (keep the top left button pressed for 2 seconds to change)

To reset the counter of the last take duration when cahnging the magazine, press once the red button on the Motor Driver box and the counter will start from (T:000)

To put the camera in motion we must press the red button labeled **CAMERA**. The message **OFF** changes to **ON**. To turn off the camera, press the camera button once more and the message will return to **OFF** as the camera switches off. From this screen you can also access specific information relating to the Zoom, Iris and Focus controls. The potentiometers for each control have been given specific scales between 000 and 999

so that proper calibration can be inspected at any time. These scales also offer the user an extremely accurate reference of lens position. To access this menu, press the top right hand button the following message will appear on the lower right hand side of the screen **F: 632** (this number depends on the position of the focus

command); if the **Focus** pot is well calibrated the 3 digits will vary from around **000** up to **999** corresponding to the ends of the commands. If the potentiometer is well calibrated and operating properly, when you move the control knob up and down, press the button again the message **I: 854** will appear, (like for focus the number will depend on the position of the iris pot). Now we can check the calibration of **Iris** the same way as **Focus**. Pressing the button again we can read **Z:000** to check the zoom. If we press the **Zoom** control upwards this value should appear **999**. Pressing it down should produce **000**.

With the key **SEL** we can go to the next screen.

5.LIMITS

The next 3 screens pertain to specific programs that may be implemented on each of the three controls of the hand unit, such as programming limits in the **Focus**, **Iris** and **Zoom** range. The three screens will appear in the following order as we press the (**SEL**) button to change the screen:

To reverse the direction of the Focus, Iris, or Zoom controls, press the top left- hand button. After pressing this button, the arrow on the display will changes its direction. The control that has been changed will now turn the corresponding motor in the opposite direction. To change back to its original direction, press the button once more.

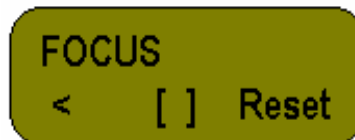

With the center button you can program the run of the optical lens between two specific limits within the full mechanical range of the lens. The method of setting **Focus** limits is the following:

- 1°. Rotate the Focus Knob until the lens reaches the desired position for the 1st limit.
- 2°. Press the center button and keep it in this position.. The following screen will appear.

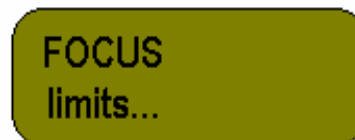

3°. While holding the button down, move the focus knob to the second limit. Next, release the button and the entire range of the focus control will operate within the two limits that have just been programmed.

To recover the total optical run, press the top right button **Reset**.

By pressing **SEL** we go to the next screen (limits for **IRIS**).

The limits for **Iris** are set using the same method as for the **Focus** limits.

To program limits within the **Zoom** range, the procedure varies slightly:

- 1°. Move the lens to the desired position for the first limit.
- 2°. Press the central limits button ([]). The following message will appear for a moment: **User limit 1**
- 3°. Release the button, and move the lens up to the 2nd desired position.
- 4°. Press the top-center button and for few seconds the following will appear **User limit 2**

To reset limits simply press reset, and the motor for each given function will re-calibrate for the entire range of the lens.

To change the screen press **SEL**

6. MECHANICAL STOPS

To find the mechanical end stops of the lens (**Reset**). This must be done when you change the camera optics in order to re-calibrate the system. Re-calibration may also be initiated, by disconnecting the motor cables. The system senses that there is an interruption in power, and will automatically reset the motor that has been disconnected. You can reset each motor individually by pressing the corresponding button beneath each option on the menu above.



FOR OPERATION WITH THE SCORPIO REMOTE HEAD ONLY.

7. MOVING THE HEAD

From this screen we can control the head movement from the focus command. When we have this display, there is a question mark to confirm that you would like to control the head by the focus command.



This program is intended so that the camera assistant who changes the magazine can control the head but the person at the central control unit cannot. This function is also useful in setting up future shots. With this program engaged, the control unit is completely overridden..

If you press the top left-hand button, the message **OK** appears which tells us that from this moment, you can control all three axes (**PAN**, **TILT**, and **ROLL**). The **Zoom** pot controls the **PAN** & **TILT** axes, while the **ROLL** axis is controlled through the two top right-hand buttons.

If you enter this screen but you cannot move the head, it means that this option has been locked out by the Central control Unit (Handwheels, Joystick or Pan-Bar system).

With the lower right potentiometer you can adjust the maximum speed of the **PAN**, **TILT**, and **ROLL**. The speed of **PAN** and **TILT** also depends on the pressure exerted on the **Zoom** pot. The movement of the **ROLL** axis is achieved by pressing the 2 top right hand buttons; each one turns the head in a different position.

To return control to the **Handwheels** the **Joystick** or the **Pan-Bar system** it is only necessary to press **SEL**.

8. FILM SIZE (16/35 mm)

On this screen we can select the film size for your application by pressing the top left-hand button for **16 mm** or the top-central button for **35 mm**.

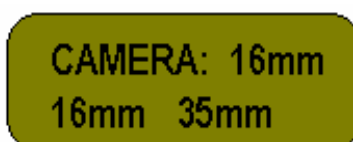

9. POWER LEVEL'S SELECTION FOR ZERO'S SEARCHING (MOTOR POWER)

From this screen we can select the power level for searching the FIZ motor optic tops to adjust the force of these motors to the used optic. The active level is indicated by the blinking characters to each one of the motors. We can memo a different power choosing between low L, media M & high H, pressing each one of the corresponding buttons to each one of the motors. This option is also recorder in memory after switching off the equipment.

**10. SELECTION OF POWER LEVEL FOR THE MOTORS**

The function of this screen is the same as the last one. The only difference is that the memorized power will be the one that motors will have as the normal working.

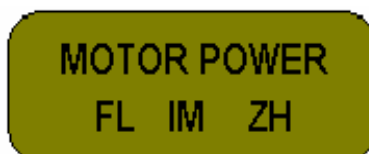
**11. LIMIT ADJUSTMENTS**

To access this menu, switch on the hand unit while holding down the top-center button. Continue to hold down the top central button until the menu "Manufacture Adjustments" appears. From this menu you can calibrate the Zoom, Focus, Iris and External Iris potentiometer as well as select the radio communication standard (depending on the country) and the channel through which the information will be send.

This is the screen that will appear first:



The screens will appear in the following order by pressing the SEL button:

- 1.- Zoom potentiometer calibration.

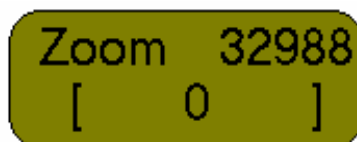

Hold the zoom potentiometer downwards. Then press the top left-hand button once to calibrate the lower region of the potentiometer (minimum value). Next, hold the potentiometer upwards then press the top right-hand button to calibrate the higher region of the potentiometer (maximum value). Finally, release the pot and press the top-center button once.

2.- Calibrating the zoom potentiometer as Zapper. (For remote Head Control)

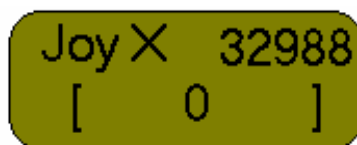

Follow the same procedure as above, but hold the potentiometer to the left to calibrate the left-hand region, and hold the potentiometer to the right to calibrate the right region.

3.- Focus potentiometer calibration.

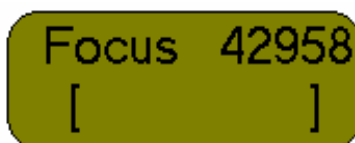

Rotate the focus control knob in the direction that causes the numbers on the display to count downward until you reach the mechanical limit of the knob. Now rotate the knob back slightly so it is few degrees from the end of the mechanical limit. Now press the top left-hand button once. Then rotate the Knob in the opposite direction until it reaches the other end. Rotate the Knob back slightly so it is a few degrees from the mechanical limit. Now press the top right-hand button.

4.- Iris potentiometer calibration.

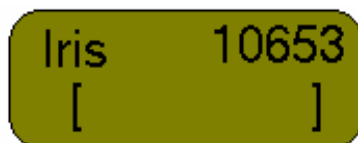

Slide the Iris control in the direction that causes the scale to count downward. Slide the control in this direction until it reaches the end. Slide the control back a few degrees and press the top left-hand button. Now slide the control in the opposite direction until it reaches the other end. Slide the control back a few degrees and press the top right-hand button.

5.- External iris calibration.

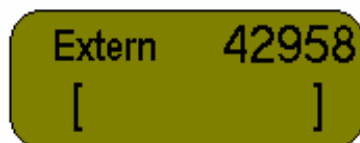

Follow the same procedure described in the Focus potentiometer calibration section.

6.- Wireless communication standard selection.

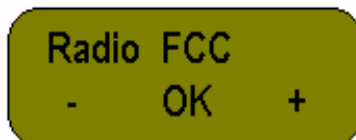

By pressing the “+” and “-“ buttons, one of the following standards can be selected: **FCC, IC, ETSI, SPAIN, FRANCE and MKK** (the number of channels for each standard depends on the regulations for each area). After the standard for the area you are operating the system in is on screen, press the top-center button to activate

7.- Transmission channel selection.

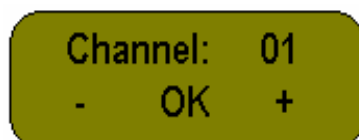

As mention above, the number of channels available varies depending on the standard activated. Press the **OK** button to activate the operation channel. (It is now recorded in the memory).

It is also possible to select the transmission channel directly, switching on the hand unit while holding the left-top button. Then switch off the hand unit.

NOTE: After any of the displays had been adjusted, disconnect the power of the motor driver box and connect it again.

12. MESSAGE TO CHANGE BATTERY (LOW BAT !!)

When the battery is at low capacity, the system sends a message announcing that in order to maintain proper operation, the battery must be changed soon. At this point, the voltage supplied by the battery is sufficient to work with, but it is strongly recommended that you change the battery. You will notice a letter **B** now appears on the right-hand screen as warning.

When the level is so low that you cannot continue to work with the command, the following screen appears:

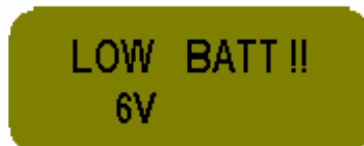

13. SPECIAL OPTIONS (Speed/iris/shutter compensation)

You can access the special options menu by holding the top-center button for more than two seconds. Once you have accessed the menu, the following screen will appear:

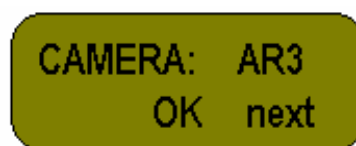

From this screen, various camera control program and the motion generator program can be entered. The Analog camera program (ARRI III, BLIV or SRII) allows you to program iris position changes to compensate for increased or decreased film speed. The Digital camera program (ARRI 435 or 535) allows you to program changes in camera speed, iris positions, and shutter angle.

Press the **next** key to select the camera you are using and press **OK** to activate the program.

- **Analog cameras and SR3**: This program allows you to program a minimum and a maximum camera speed and record until 30 iris positions. After the program is set and the camera is operating at a speed between the minimum and the maximum speeds that have been recorded, the iris will automatically adjust position

depending on the recorded points. The result will be that the picture will maintain a constant bright level for all speeds, thus eliminating the need to control the iris manually .

- Camera SR2 example: press the **next** button we can select camera SR11. Press the **OK** button to change to the following screen:

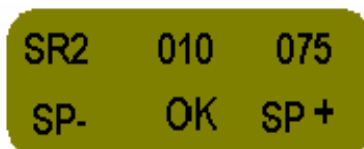

In this menu you select the minimum and maximum speed values between which the camera will work. The first character **S** indicates speed, the following 5 indicate minimum speed (3 integers and 2 decimals) and the last 5 are for maximum speed (3 integers and 2 decimals). By pressing **OK** you change from digit to digit and by pressing buttons **SP+** and **SP-** you can increase or decrease the speed.

After activating minimum and maximum speed, press **SEL** button. From the following screen, you can program 30 iris position points corresponding to 30 speed values between the minimum and maximum speeds.

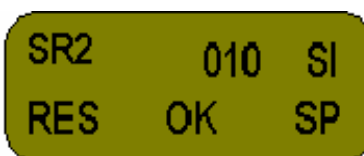

Press the **RES** button and hold it until it blinks to clear the memory bank of any values that have been previously recorded. It is advisable to always clear the memory before starting a new program. After pressing the **RES** button, the three digits that indicate camera speed will automatically change to the minimum speed value you have programmed. Now move the iris into the starting position at the minimum speed value. Then press **OK**. Now move to the next speed you would like to program an iris change at by pressing the **SP** key until you reach the desired speed. When this value has been reached, you can then move the iris into position and press **OK**. Follow this procedure until you reach the maximum speed value, and ending Iris position. After all positions have been recorded, you can enter the next menu by pressing **SEL**.

From this moment we can make the camera speed vary between the minimum and maximum speed values recorded while the system automatically adjust the iris according to the settings you have programmed. This speed change can be controlled manually or automatically. To select the control method, press the **SEL** button and the following screen will appear:



The top line on the display indicates the type of camera controlled (**SR11** in this case) and the program activated (speed/iris, **SI**).

In the bottom line, letter **S** indicates speed, symbol **?** indicates automatic compensation ramp, and letter **Y** indicates there is connection between the focus hand unit and the FIZ box. Finally, letter **R** or **M** indicate the type of control activated (automatic ramp or manual). By pressing the top-center button you enter

The screen below. From this menu, you can set the duration time of the automatic ramp between 1 and 99 seconds.

The minimum time duration is 4 seconds for speed variations up to 50 fps, and 7 seconds for speed variations from 50- 150 fps. To set the ramp duration, use the “+” and “-“ buttons to reach the desired time. Once the time duration has been set, press the **OK** button to return to the ramp operation menu above.

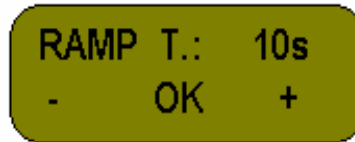

To activate the automatic ramp, first press top right hand button until the letter **R** appears. This indicates the program is set for automatic, rather than manual. Now the ramp is activated. To activate the program through the camera, first move the iris potentiometer from one end to the other. The Iris potentiometer acts as the trigger for the system. Whether you begin the program with the Iris potentiometer from the top or the bottom depends on which direction you would like to ramp to run. After the iris potentiometer is placed at one end, the symbol ? will start flickering. When the symbol ? is steady, it means that the speed variation from the minimum to the maximum (or vice versa) has finished within the time programmed. During the speed variation, the iris opening will adjust automatically depending on the points that have been recorded earlier.

To control the variation manually, first press top right-hand button until the letter **M** appears. Now camera speed can be controlled manually by varying the time duration of the ramp. You also have the option of only doing a partial ramp. By leaving the Iris potentiometer positioned anywhere along the mechanical run of the control, the system will automatically adapt the camera speed and iris position to correspond with the position that the iris control has been left at.

- Digital cameras (435 y 535): select the special options screen as described earlier. Select either 435 or 535, depending on the camera being used. Once the camera has been selected, press **OK**. The following screen will appear:

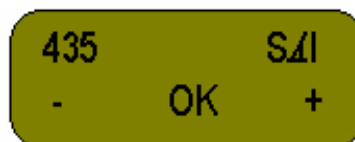

Trough the “+” and “-“ buttons, you can select the type of compensation program you would like to run. Once a program has been selected, press the **OK** button to activate the program and switch to the next screen.

Available programs for the Arri 435 and 535 are:

SI: speed/iris. Follow the same procedure that is used to program the analog cameras.

∠I: shutter/iris. This program allows to vary the shutter angle between two recorded limits while simultaneously varying the iris automatically. By selecting this option the following screen will appear:

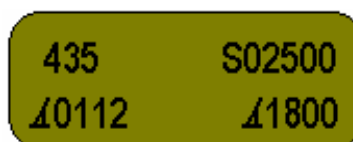

The type of camera is indicated on the top line (435). To the right, the working speed can be selected.

On the bottom line starting and final shutter positions can be set (degrees). To navigate through the screen, press top-center button. To change the values, use top-right and top-left buttons to increase and decrease values. First, program the speed you would like the camera run. Next record the beginning and ending shutter angles. When this is done, press **SEL** to move to the next menu. Now press **RESET**. As mentioned earlier, it is

always important to clear the memory of previous settings. Now move the iris to the position you would like it to be at for the beginning shutter angle. Now press OK. By pressing the \angle button, you can move to the next shutter angle you would like to assign anew iris position to. Now move the Iris to the next position, and press OK. Continue this procedure until you have reached the end values. Now press **SEL** to enter the next menu, you can choose to run the system automatically or manually, as described in the previous section.

\angle : shutter. In this option, upper and lower shutter limits and working speed can be set. The procedure is the same as shown in the above example, except the iris adjustment functions have been deleted.

S \angle I: speed/shutter/iris. With this program activated, it is possible to program two types of compensation. It is possible to set a beginning and ending camera speed while varying shutter angles to a preset compensation change speed, and then continuing on through the rest of the ramp with preprogrammed iris positions changes.

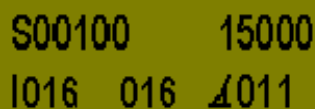

S00100 15000
I016 016 \angle 011

The letter **S** indicates speed. The next five digits indicate minimum speed (3 integers and 2 decimals). On the same line, the last five digits indicate maximum speed. On the bottom line, the first two digits are used to select the speed values to which an iris position is going to be assigned (points that will be recorded as iris changes). The next two digits located in the center of the screen represent the speed at which compensation will switch from iris to shutter angle or vice versa, depending on the direction of the ramp. The last four digits represent the shutter position. This value changes automatically when varying the compensation change speed value (central value in the bottom line).

To begin, first program the beginning and ending camera speeds. Next press the, top-center button to go to the compensation change speed (center two digits). Now program the speed at which you would like the transition to take place. The limitations of the camera will allow you to only adjust the shutter up a certain speed. If you attempt to program a shutter angle change over this speed, the system will not respond. The shutter symbol and compensation change speed characters will both blink alternately on the display, indicating that the system will not accept your command. If this happens, you must decrease the compensation change speed to an acceptable level in order for the program to operate correctly. After this speed has been set, press the top-center button to go to the iris position character (lower left-hand display).

Now move the iris to the first position and press the center button to record the position. Now press the top right-hand button to move to the next speed you would like to make an iris change. Then move the iris into position, and press the top-center button to record. Continue this procedure until you reach the compensation change speed. When this point is reached and you press the top-center button to record the last point, the menu will return to the top line (minimum speed value). You can now press SEL to go to the last menu to select either manual or automatic ramp operation.

On the ARRI 435 and 535 A, it is possible to go reverse. To access to this option, press the left-top button (S) until (SR) appears. To go forward, press again the left-top button until (S) appears:

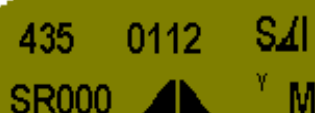

435 0112 S \angle I
SR000 \blacktriangle Y M

S∠: speed/shutter.

S00100	15000
∠0112	∠1800

In the same way as the above option set minimum and maximum speed values (top line). In the bottom line, the first shutter value varies automatically when changing the speed values. The final shutter position is always set to 180°. Press the **SEL** button to access the ramp menu to select automatic or manual ramp operation.

NOTE: Both S∠I and S∠, the shutter symbol and compensation change speed characters will both blink alternately on the display, indicating that the system will not accept the transition speed. The system is advising that the shutter doesn't arrive to the minimum range (**11.2**), so we have to decrease the compensation change speed until the digits stop blinking (**min. speed 9.34 fps**).

Press the **SEL** button to access to the last display. By pressing the top-center button we can change the ramp duration, and by pressing the top-right button select the automatic or manual ramp. If we try to change to the last display (SEL) while the shutter symbol and compensation change speed characters are blinking, the following message will appear:

SHUTTER OUT
OF RANGE

- Motion generator:

This option is used to control automatically the focus and zoom through an encoder arm attached to a dolly that travels along a length of track. After programming the system, focus and zoom will vary in relationship to the movement of the camera mounted on a dolly.

From the special options screen select the option **MOTION GEN** (button **OK**). The following screen will appear:

M.G.	F080
RES	IN

M.G. indicates that the option Motion Generator operation is selected. The three digits in the top line to the right indicate the focus potentiometer position.

M.G.	Z171
RES	F IN

The procedure is the following: move the camera (on a dolly with an encoder) to the starting position and set focus. Next press the **IN** button to record. Now move the dolly to the next point (usually when the object begins to fall out of focus), and set focus. then press **IN**. You can continue this operation until you have recorded 60 points (it is important not to go beyond this value. The system would start recording over again, losing previous positions). After recording all focus points, press **SEL**:

Now return the dolly to its original position. You can now follow the same procedure, adjusting the zoom in the same manner. Like focus, you can record up to 60 points for the zoom. Once all points have been recorded, Press **SEL**.

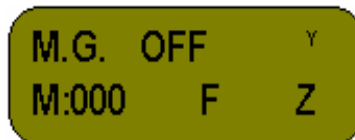

When the letters **F** and **Z** are blinking, this indicates that automatic focus and zoom are activated. They can be deactivated individually by pressing the two top-center (focus) and right-hand (zoom) buttons. If they are not activated, the letters stop blinking and then focus and zoom can be controlled from the hand unit manually. This option allows you to correct the focus manually while the recorded point by point run is being reproduced. To return to complete automatic operation, simply press both buttons again until they start to blink.

The information on the top line indicates the state of the camera (**ON/OFF**) and coverage (**Y/N**).

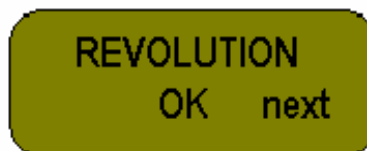

Pressing the **SEL** button accesses the normal control options menu.

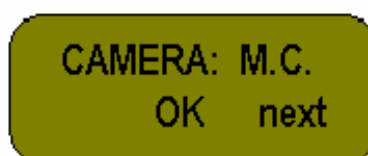

- Moviecam Camera:

By pressing OK button, and thus selecting the next screen, we will access to the special control menu for Moviecam cameras (Compact & Superamerica).

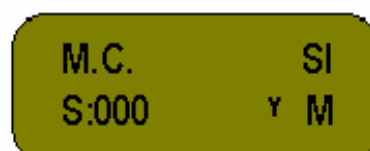

The screen that appears, indicates us the camera speed (S:000) when this is on the camera that we do control (M.C.: Movicam Compact), the compensation mode (SI: speed with Iris) and the manual control mode M or automatic R.

From this screen we activate the programmed ramp at the SPEED CONTROL in the same way that we did with the analogic and digital cameras.

14. VIDEO MONITOR

Video monitor: To connect the on-board video monitors option; attach the monitor to the optional monitor support. Then connect the # 5435 power cable from the monitor input to the yellow 4 pin Lemo connector situated on the back of the command.

Scorpio Head Operation only: When used in conjunction with the Scorpio Remote Head, the video button on the command allows you to select between 3 video channels. Two channels are available in the panel connected to head and the control system (**Handwheels, Joystick, and Pan-Bar system**) and the third, which corresponds to the signal given by the wire connected to the VIDEO EXTERNAL connector in the back part of the control.

To use the monitor with the Scorpio remote Head, the switch 2 on the back panel of the control (Page 1 of the **Head Control Manual**) must be in one of its two positions when the Focus Command Hand Unit is connected to the connection. It must be switched to the other position when the Hand Unit is connected directly to the control unit.

15. SERVO BOX (FIZ)

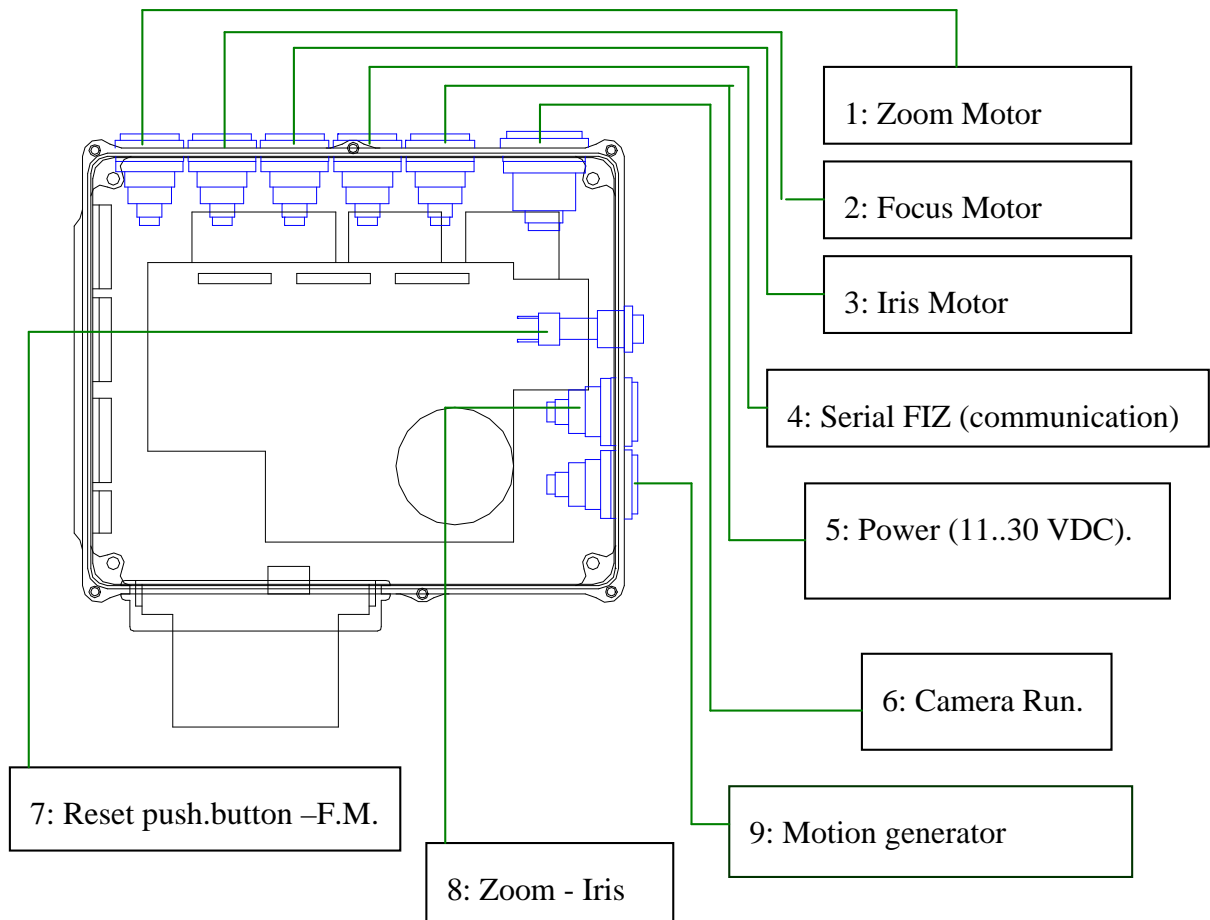

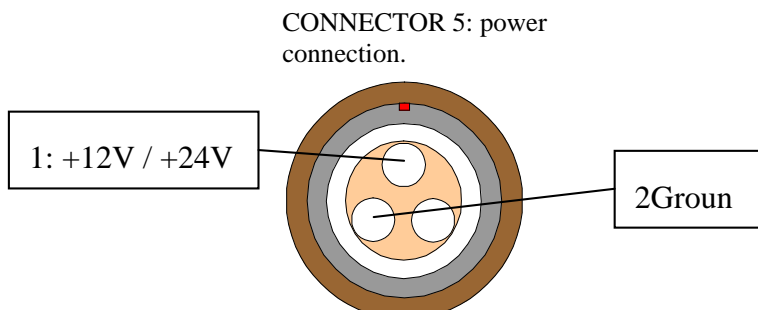
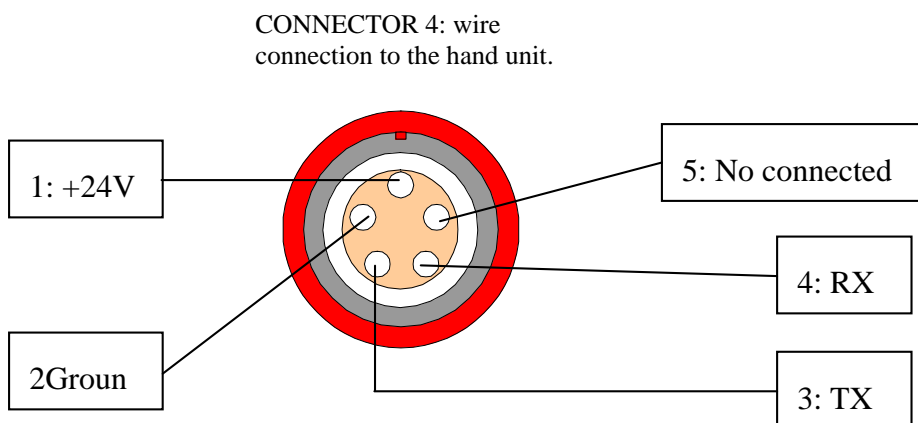
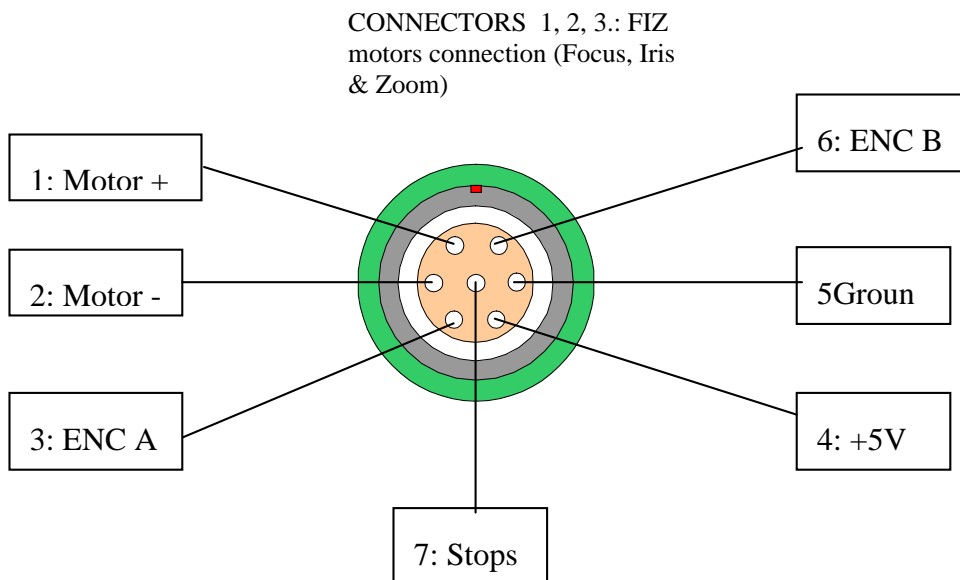

CONNECTOR 6: driver cables
and speed/iris/shutter
compensation connection.

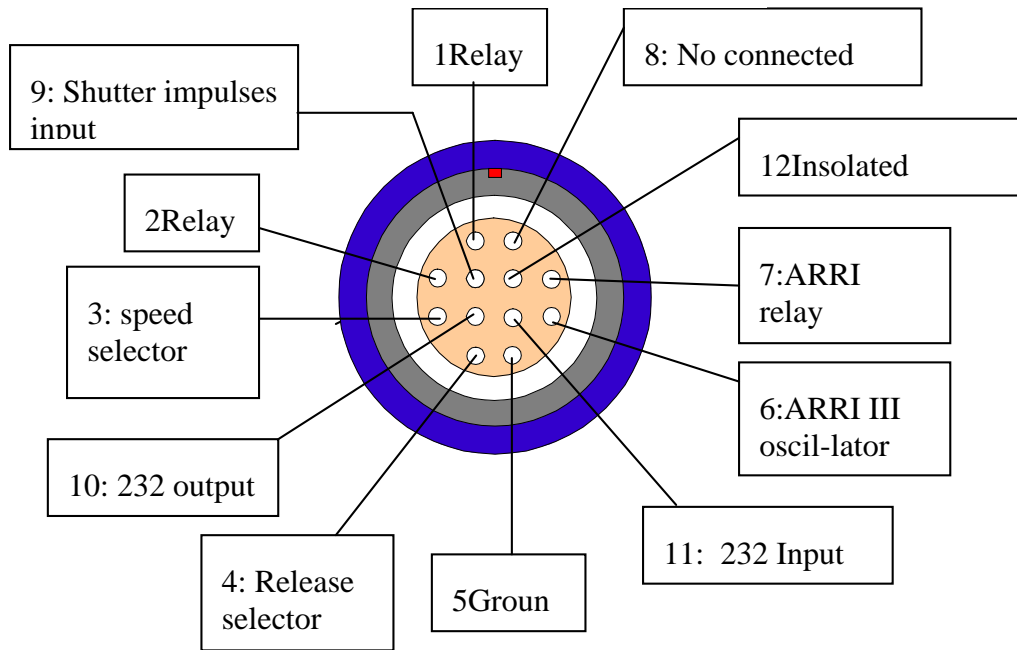

CONNECTOR 7:
zoom/iris command
connection

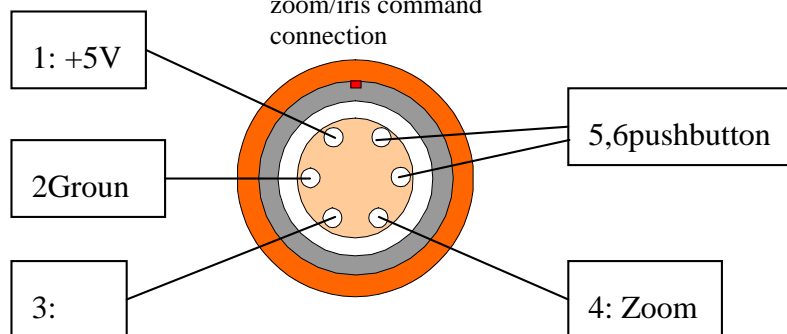

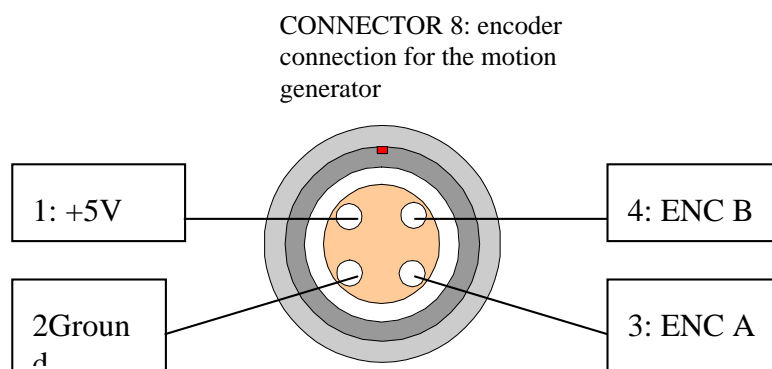

16. HAND UNIT BACK CONNECTORS

On the back part of the hand unit there are the connections for the 6v battery and 3 other connectors:

- 4 pin Lemo connector: monitor connection.
- 6 pin Lemo connector: Iris/Zoom command (Ref. 2006) connection. If this command is connected, it overrides the iris and zoom control on the hand unit.
- 7 pin Lemo connector: power and communication wire connection. Hard wire connection.

Index.

1. DESCRIPTION OF THE FRONT PANEL.....	Pág. 1
2. SWITCHING ON.....	Pág. 1
2.1. WIRE CONNECTION.....	Pag. 1
2.2. WIRELESS CONNECTION.....	Pag. 2
3. RESET ALL.....	Pag. 2
4. MAIN SCREEN (speed and meters shot).....	Pág. 3
5. LIMITS.....	Pág. 4
6. MECHANICAL STOPS (RESET MOTORS).....	Pág. 5
7. MOVING THE SCORPIO HEAD.....	Pág. 5
8. FILM SIZE.....	Pág. 5
9. POWER LEVEL SELECTION (MOTOR POWER).....	Pág. 6
10. SELECTION OF POWER LWVWL FOR THW MOTORS.....	Pág. 6
11. LIMITS ADJUSTMENTS.....	Pág. 6
1.- Zoom potentiometer calibration.....	Pag. 6
2.- Calibrating the zoom potentiometer as Zapper.....	Pag. 7
3.- Focus potentiometer calibration.....	Pag. 7
4.- Iris potentiometer calibration.....	Pag. 7
5.- External iris calibration.....	Pag. 7
6.- Wireless communication standard selection.....	Pag. 7
7.- Transmission channel selection.....	Pag. 8
12. MESSAGE TO CHANGE BATTERY.....	Pág. 8
13. SPECIAL OPTIONS (Speed/iris/shutter compensation).....	Pág. 8
- Analog cameras and SRIII.....	Pag. 9
- Digital cameras (435, 535).....	Pag. 10
- Motion generator.....	Pag. 12
- Moviecam Camera.....	Pag. 12
14. VIDEO MONITOR.....	Pag. 14
15. SERVO BOX (FIZ).....	Pag. 14
16. HAND UNIT CONNECTORS.....	Pag. 17